

* I N S T R U C T I O N M A N U A L *

144MHz Band/430MHz Band
DUAL BAND POWER AMPLIFIER
Model HL-725D

TOKYO HY-POWER LABS., INC.

FEATURES

HL-725D is a dual band power amplifier for 144MHz/430MHz band, with a low noise GaAs FET RX preamps. Using a large heat sink and the circuits of our well established HL-62V and HL-60U models, HL-725D has achieved a high reliability and stability. You can enjoy not only an effective operation of TX/RX amps, but also simultaneous preamp operation of both 144/430MHz bands. And furthermore you can enjoy various operations of as much as 13 kinds combination of dual TX/RX amplifiers, as respective IN/OUT connectors are installed independently. This combination is shown in the table appearing later.

SPECIFICATIONS

	144MHz band	430MHz band
Mode :	FM/SSB/CW	
DC Power :	DC 13.8V(12-14V) negative ground	
Power Consumption :	8A max.	9A max.
Output Power :	50W(10W-60W)	50W(5W-60W)
RF Input Power :	10W(1W-15W)	12W(1W-15W)
IN/OUT Impedance	50Ω	
IN/OUT Connector	M(S0239) x 2	M(S0239) x 2
RX Preamp Gain	Approx. 15dB	Approx. 15dB
Accessory Circuit	1.GaAs FET low noise RX preamps 2.COX 3.MODE select switch 4.T/R remote control terminal 5.Reverse DC power polarity protection (6.Over drive protection/144MHz amp)	
Semiconductors	RF power transistor x 2 GaAs FET x 2 Transistor x 12 Diode x 40 LED x 5	
Fuse	10A	
Accessories	Mobile mounting bracket M-M jumper cable x 2 Fuse DC power cord(with conector)	
Dimensions	250(W) x 42(H) x 173(D) mm	
Weight	Approx. 2.7 Kg	

EXPLANATION OF FRONT AND REAR PANEL FEATURES

*Front panel

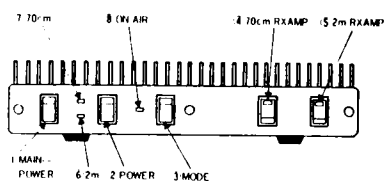

*Rear panel

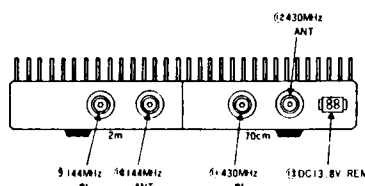

(FIG.1)

- ① MAIN-POWER(Main switch)
Main power switch for TX amplifiers
- ② POWER(70cm-2m select switch)
Select power supply for TX amp. to either 70cm or 2m.
(It is not possible to transmit(make amplification state) on both 70cm band and 2m band at the same time.)
- ③ MODE(mode select switch)
The change-over from TX(send) to RX(receive) is made with some delay of approx. 1 second at SSB mode, so that the relay does not chatter on 2m band. At FM, the change is made instantly.
At CW, set this switch to SSB mode. (70cm circuit uses a quiet diode change-over switch)
- ④ 70cm RX AMP(RX amp switch for 70cm band)
Power switch for RX preamp of 430MHz band.
At "ON" state, LED attached to this switch lights.
It can be operated independently even if MAIN-POWER switch is off.
- ⑤ 2m RX AMP(RX amp switch for 2m band)
Power switch for RX preamp of 144MHz band.
At "ON" state, LED attached to this switch lights.
It can be operated independently even if MAIN-POWER switch is off.
*Besides, RX amps for both 70cm and 2m can be operated at the same time.
- ⑥ 2m pilot lamp
This lamp indicates the power amp for 144MHz band is on.
- ⑦ 70cm pilot lamp
This lamp indicates the power amp for 430MHz band is on.
- ⑧ ON AIR pilot lamp
This lamp indicates the power amp for either 144MHz or 430MHz is transmission state.

- ⑨ 144MHz IN connector
Input connector for 144MHz band.
Connect the cable from antenna connector of 144MHz transceiver.
- ⑩ 144MHz ANT connector
Antenna connector for 144MHz band.
Connect the cable from 144MHz antenna.
- ⑪ 430MHz IN connector
Input connector for 430MHz band.
Connect the cable from antenna connector of 430MHz transceiver.
- ⑫ 430MHz ANT connector
Antenna connector for 430MHz band.
Connect the cable from 430MHz antenna.
- ⑬ DC13.8V/REM. connector
Connector for DC power cord and remote control cable.
As to connection of remote control cable, please refer to "PREPARATION BEFORE OPERATION" on page 4.

CONNECTION OF COAXIAL JUMPER CABLES

Input/Output connectors(Total : 4 connectors) are installed on the rear panel of HL-725D for 144MHz band and 430MHz band respectively. There are various ways of connections depending on the type of transceiver and antenna etc. In some cases, optional parts(E.G. antenna switch, duplexer etc.) are needed.

Followings are connecting examples.

- 1) Monoband transceiver(or dual band transceiver with 2 independent ANT connectors) + Monoband antenna

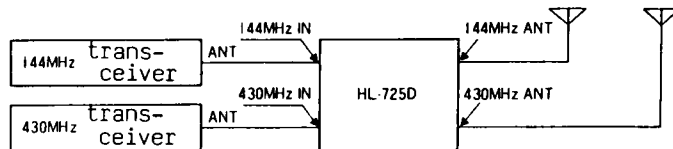

- 2) Monoband transceiver (or dual band transceiver with 2 independent ANT connectors) + Common antenna

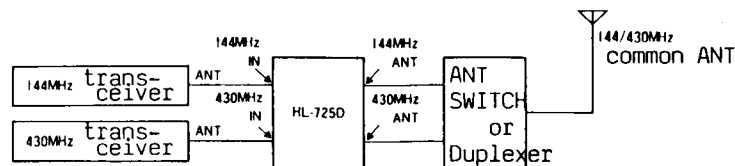

3) Dual band transceiver with one antenna terminal + Monoband antenna

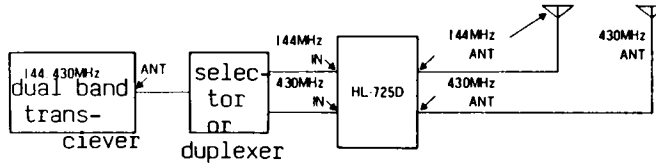

4) Dual band transceiver with one antenna terminal + Common antenna

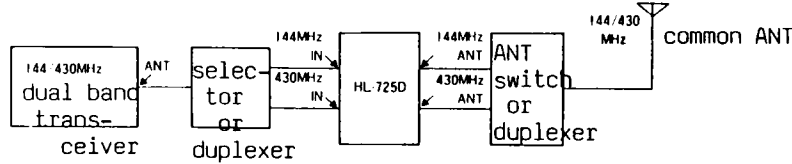

- Note :
- ① In case of using antenna select switch, choose a good one for insertion loss, SWR and withstanding a high power at 430MHz band.
 - ② Use short and good jumper cables of 5D2V or upper grade, to reduce insertion loss.
 - ③ In case of using a transceiver with one antenna terminal or common antenna of 144/430MHz, don't connect simply in parallel at input(IN) or output(ANT) terminal of HL-725D, or it may be a big mismatch, and it will kill the transistor at final stage of HL-725D or transceiver.

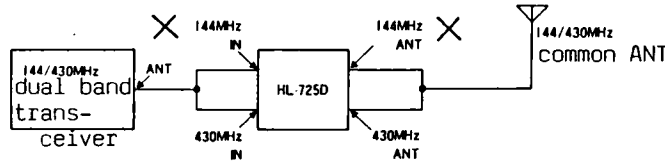

PREPARATION BEFORE OPERATION

1) For complete remote control operation from transceiver, connect wires from DC13.8V/REM. connector on the rear panel of HL-725D to "Stand-by" terminal or equivalent of the transceiver.

① Connection

a. Connecting to the terminal or circuitry which comes to DC +3V - 9V on transmission at the transceiver.

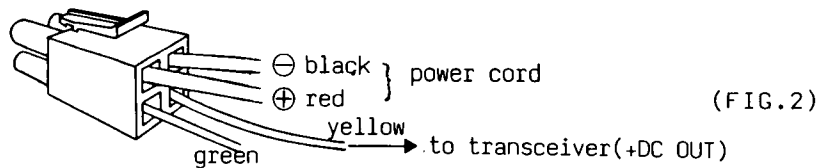

b. Connecting to the terminal or circuitry which is made short on transmission and open on reception at the transceiver.

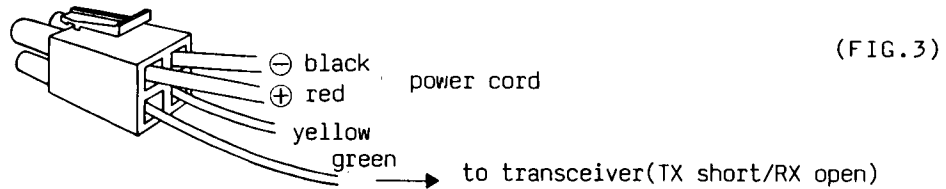

Note : 1) Read the instruction manual of your transceiver to decide the connection of a. or b.
 2) For grounding, it's common to the coaxial jumper cable from antenna connector of the transceiver.

② In case of using two monoband transceivers, connect between the device and transceivers further as follows.

a. +DC circuitry

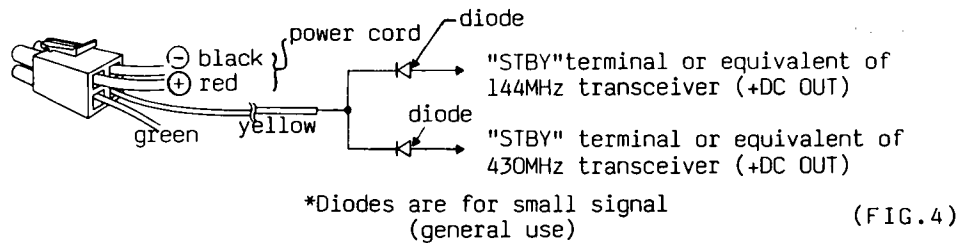

b. Short/Open

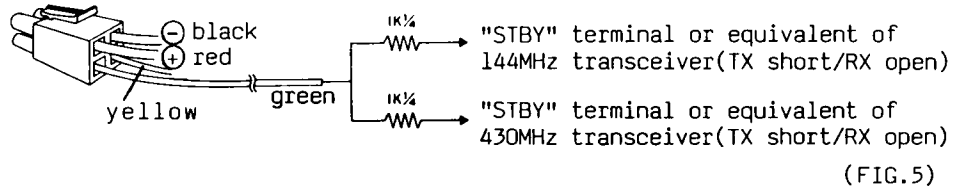

*CAUTION : If you don't operate with remote control, remove vinyl coated wire for remote at the transceiver and insulate the end of wire not to touch the metal case, and bundle the wire.
 If the wire(not insulated) touches metal case, transceiver may get a trouble, or HL-725D may operate erroneously(not to switch to RX).
 Please be careful of treating the wire.

2. Connect cables as required according to "CONNECTION OF COAXIAL JUMPER CABLE" on page 3.

3. Connect power plug to ⑬ DC13.8V/REM. connector on the rear panel of HL-725D.
4. In case of remote control operation, connect cables for remote control which are prepared according to the above "1. For remote control operation", to STBY terminal or equivalent of the transceiver.
5. Check if ① MAIN-POWER switch and two RX AMP switches (④ and ⑤) of HL-725D are kept off, and check the polarity of power cords (red for positive, black for negative). Then, plug it into the power supply.
6. Turn the power switch of transceiver on, and make reception state. Check if receiving signal of each 144MHz and 430MHz is heard.
7. Measure SWR value of antenna.
At first, keep all switches of HL-725D off, and measure with output power of the transceiver only. Check each band according to following FIG.6.

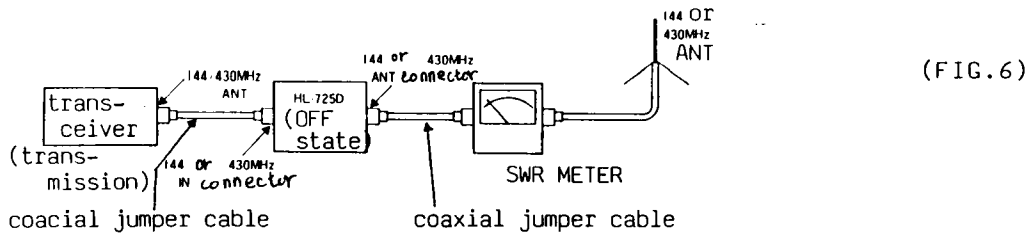

8. If SWR is too high, good transmission can't be achieved and it may be a cause of trouble for HL-725D with load mis-matching. Adjust antenna height or length of cable or setting place etc. to lower SWR value to 1.3 or hopefully as low as 1.
9. For setting the amp under the dash board panel of automobile with an attached mobile mounting bracket, install according to following FIG.7.

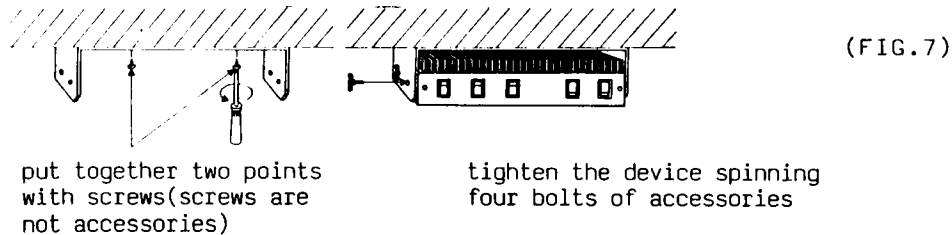

CAUTION

Be careful of following subjects which may become the cause of trouble.

1. During transmission, the heat sink may reach a high temperature (approx. 60°C - 80°C). Set the amp at a well-ventilated place. Don't put objects on top of the amp.
2. As the same way, don't operate the amp at places where is exposed to the direct rays of the sun, or nearby a heater etc.
3. Be sure to check the "Matching" or VSWR of antenna before operation. Measure "SWR" value by using SWR meter, according to FIG.6 on page 6. In case SWR value is too high, adjust your antenna length or the length of coaxial cable to obtain lower SWR value. You had better obtain SWR value of less than 1.3 or hopefully as low as 1.
4. Choose a good antenna which withstands a high power, or SWR is degraded by heat within several minutes after starting transmission.
5. Please be sure to check the connection of antenna not to kill the power transistor. Don't forget to connect antenna, don't connect the antenna of other frequency, don't mis-set the selector reversely such as 144MHz operation with 430MHz antenna or the other way.
6. Be careful that DC power voltage and driving power are kept no higher than standard specified level. The amp will not be killed immediately, but it is most dangerous, if such other bad conditions occur simultaneously, as antenna mismatch or operation at highest limit.
7. In case of using stabilized DC power supply, some DC power supplies produce abnormally high output voltage due to high frequency RF intrusion, which will kill the amp. Use a DC power supply fully protected against high frequency intrusion.
8. Don't open and touch the internal part of the device.
9. Don't change the internal wiring to transmit both 144MHz and 430MHz at the same time, or heat sink may overheat within a short time and power transistor may be killed. So please don't change the wiring related to operations of two power amps.

OPERATION

1. Check if ① MAIN-POWER switch and both ④ and ⑤ RX AMP switches are off.
2. Check if each connection is correct.
3. Set ② POWER(70cm-2m select switch) to the transmitting frequency.
4. Set ③ MODE switch to the operating mode.
5. Set ① MAIN-POWER switch on.
6. Turning the transceiver to "transmit", the device is made to "transmitting power amplification" state, and high power signals are emitted from antenna. At the same time, ⑧ ON AIR pilot lamp lights.
7. At the above 6 state, measure SWR value of antenna gain according to FIG.6 on page 6. If SWR value is high, adjust to lower SWR value as the same way.
8. At the receiving state, in case that the receiving signals are weak and hard to catch, set ④ or ⑤ RX AMP switch on. Noises are reduced and you can hear signals more clearly.
9. In case of local QSO and the function of the device is not needed, just set ① MAIN-POWER, and ④ and ⑤ RX AMP switches off.
10. In case of RX preamp operation only, set RX AMP switch ④ or ⑤ on with ① MAIN-POWER switch off.
11. Auto-return type overdrive protection circuit is built in the power amp for 144MHz band to care the operation with high-power transceiver of over 10W. If driving power exceeds 15W, attenuator will be put into the input line automatically to reduce driving power momentarily for protecting power transistor. When protection circuit has operated, there is no indication for its operation. However, by using a current meter or a directional power meter at output stage, you can see that the protection circuit has operated as meter indication is reduced. Although the protection circuit has operated, output power will not be reduced lower than 40W and it will hardly affect the communication. But resistors of the attenuator can be overheated, so please be careful of operating with a high-power transceiver. Drive with reduced power of under 10W output by selecting output level switch to "LO". When driving power is reduced to the rated level(or less) during the operation, protection circuit is released automatically and normal operation can be achieved.
12. RX preamps of 144MHz and 430MHz can be operated at the same time.

You can enjoy 13 kinds of operations according to the following diagram on page 9.

	independent operation				alternate operation				simultaneous operation				alternate(O) + constant(●) operation	
2m TX AMP	<input type="radio"/>				<input type="radio"/>		<input type="radio"/>		<input type="radio"/>				<input type="radio"/>	
70cm TX AMP		<input type="radio"/>				<input type="radio"/>		<input type="radio"/>		<input type="radio"/>				<input type="radio"/>
2m RX AMP			<input type="radio"/>		<input type="radio"/>			<input type="radio"/>		<input type="radio"/>	<input type="radio"/>		<input type="radio"/>	<input checked="" type="radio"/>
70cm RX AMP			<input type="radio"/>		<input type="radio"/>	<input type="radio"/>		*	<input type="radio"/>		<input type="radio"/>	*	<input checked="" type="radio"/>	<input type="radio"/>

* You should select receiving frequency which is kept away from 2m TX spurious.

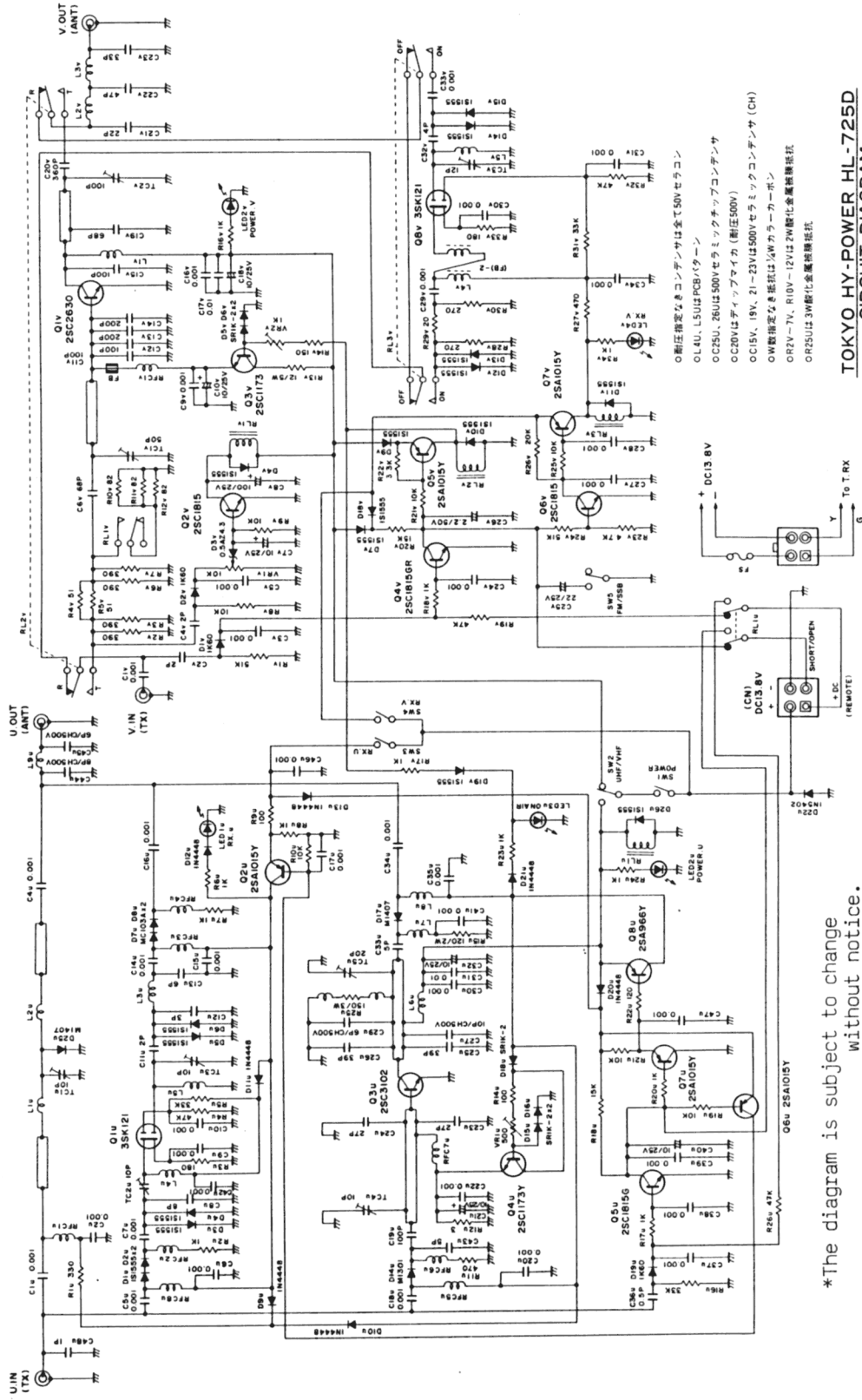

- 断圧指定なきコンデンサは全て50Vセラコン
- L4U, L5UはPCBパターン
- C25U, 26Uは500Vセラミックチップコンデンサ
- C20Vはチップマイカ (断圧500V)
- C15V, 19V, 21-23Vは500Vセラミックコンデンサ (CH)
- W数指定なき抵抗は1/4Wカラーコーン
- PR2V-7V, R10V-12Vは2W酸化金属膜抵抗
- PR35Uは3W酸化金属膜抵抗

TOKYO HY-POWER HL-725D
CIRCUIT DIAGRAM

*The diagram is subject to change without notice.